

FOR HEATER CRATE

REVISION D

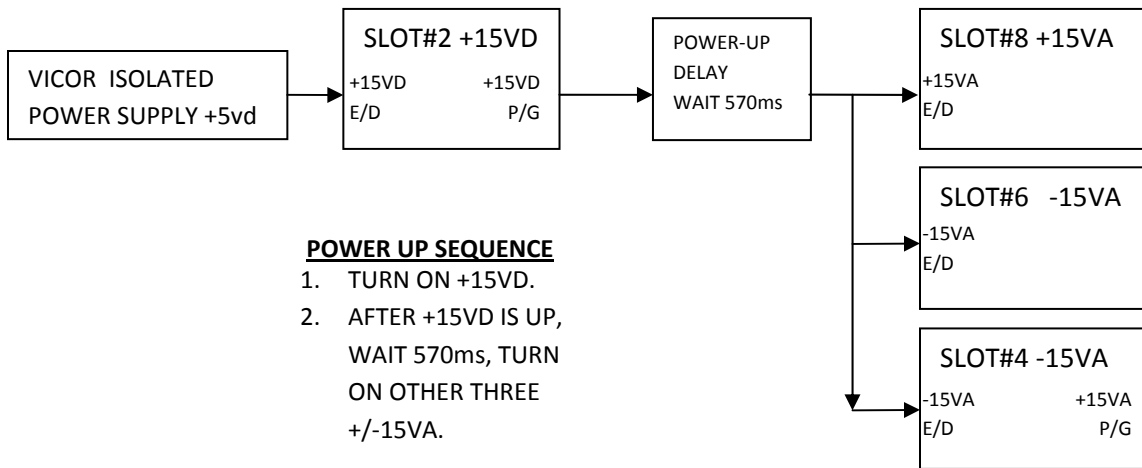

P/G CABLE NOTE: ONLY USE SLOT2 P/G SIGNAL:

INSERT DIGITAL POWER GOOD CABLE (+3.3VD ON DAQ CRATE). INTO SLOT2 (+15VD) P/G CONNECTOR. SLOT1 (+5VD ON DAQ CRATE), SLOT3 (+48VA ON DAQ CRATE), SLOT4 (-28VA ON DAQ CRATE), SLOT5 (-15VA ON DAQ CRATE), SLOT6(+15VA ON DAQ CRATE), SLOT7 (-5VA ON DAQ CRATE), & SLOT8 (+5VA ON DAQ CRATE) P/G CABLES ARE NOT USED & THUS NOT CONNECTED TO ANY P/G CONNECTORS.

POWER DOWN SEQUENCE

1. 570ms AFTER ICC BOARD GEN. SHUTDOWN OR A/C OK IS ASSERTED, TURN OFF ALL FOUR +/-15VA.

