

FOR DAQ CRATE

REVISION D

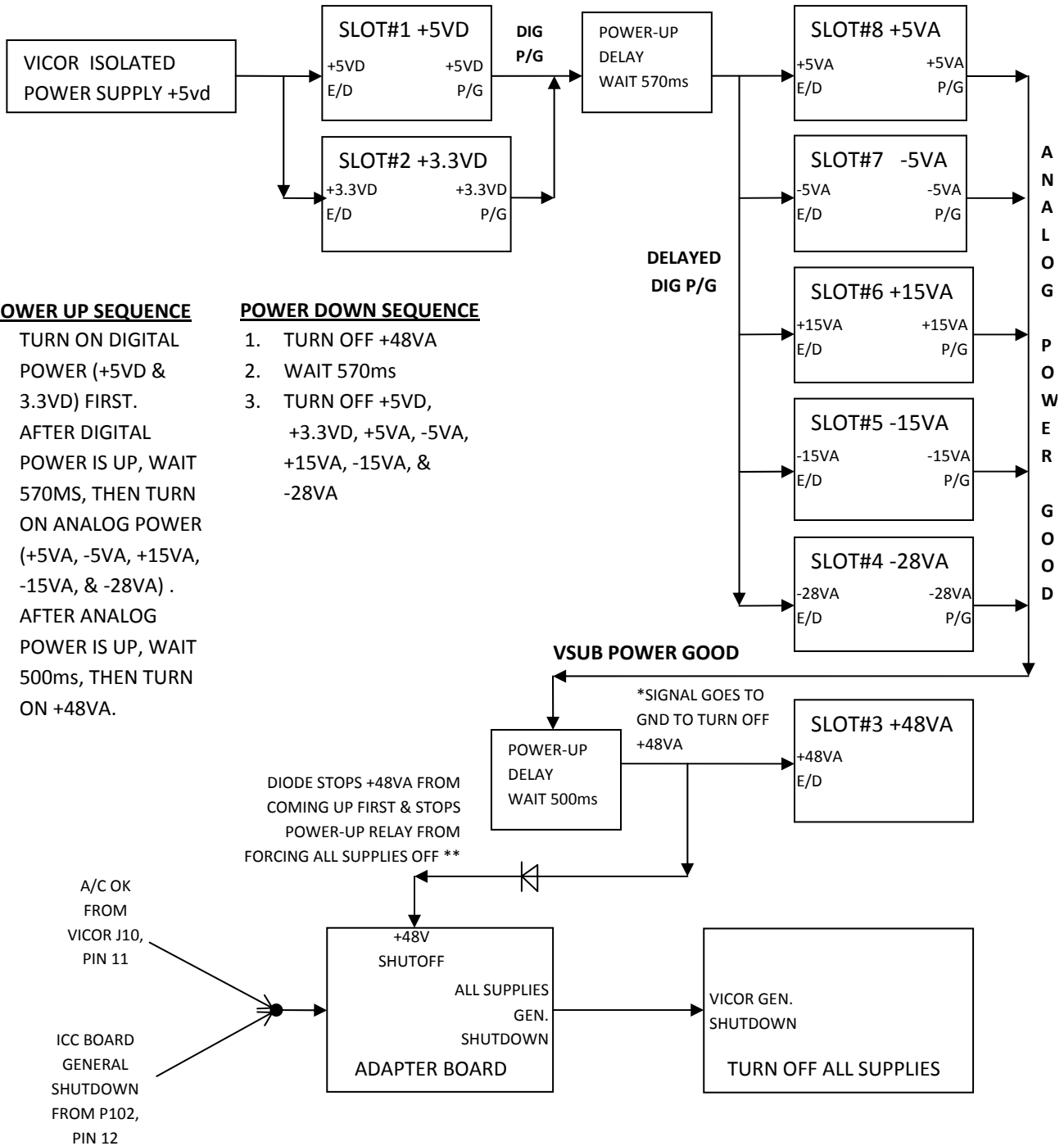

POWER UP SEQUENCE

1. TURN ON DIGITAL POWER (+5VD & 3.3VD) FIRST.
2. AFTER DIGITAL POWER IS UP, WAIT 570MS, THEN TURN ON ANALOG POWER (+5VA, -5VA, +15VA, -15VA, & -28VA) .
3. AFTER ANALOG POWER IS UP, WAIT 500ms, THEN TURN ON +48VA.

POWER DOWN SEQUENCE

1. TURN OFF +48VA
2. WAIT 570ms
3. TURN OFF +5VD, +3.3VD, +5VA, -5VA, +15VA, -15VA, & -28VA